

# Application Note: DC Applications with Haefely Mains CDNs

## 1. Introduction

All Haefely power line CDNs can be used in DC applications. However, using the CDNs with DC is completely different from using them with AC. So this application note describes the specific limits given by the different CDNs.

Switching the mains power on is much the same with DC as it is with AC. The difference is in switching the power off. Switching off any current (either AC or DC) causes an electric arc between the contacts of the opening switch. For AC there are zero crossings in the voltage which extinguish the arc. But for DC there are no zero crossings in the voltage, so the arc can extinguish only when the contacts are opened to a sufficient distance. For this reason, the voltage and current rating of the CDN is reduced for DC applications.

Listed below are the voltage and current limits for the Haefely CDNs. The given limits must not be exceeded. This can cause extreme heating in the contactors inside the CDNs and the current flowing through the EUT may not be safely interrupted!

If the given EUT limits are lower than the rated current of the CDN, the user has to protect the CDN and the EUT against overcurrents, e.g. with a suitable fuse or safety switch.

## 2. How to connect Haefely CDNs to DC

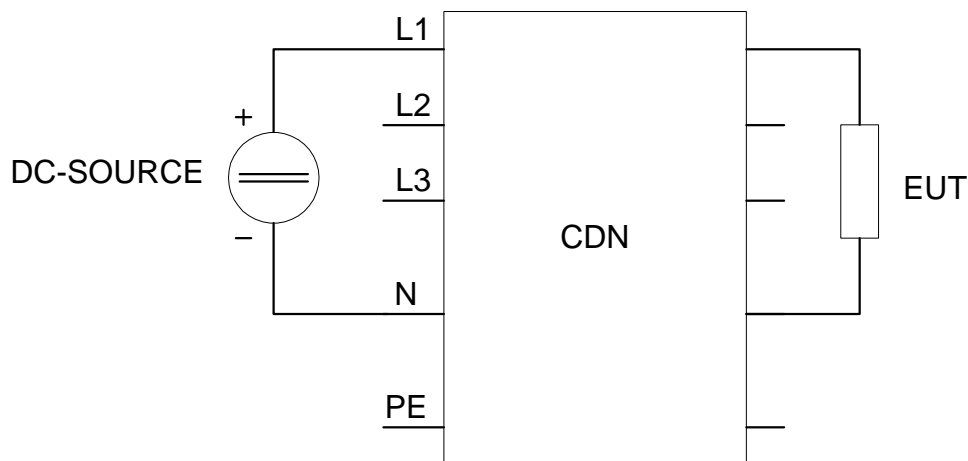

Figure 1: Two terminal source (+ and -), floating, EUT is fully isolated

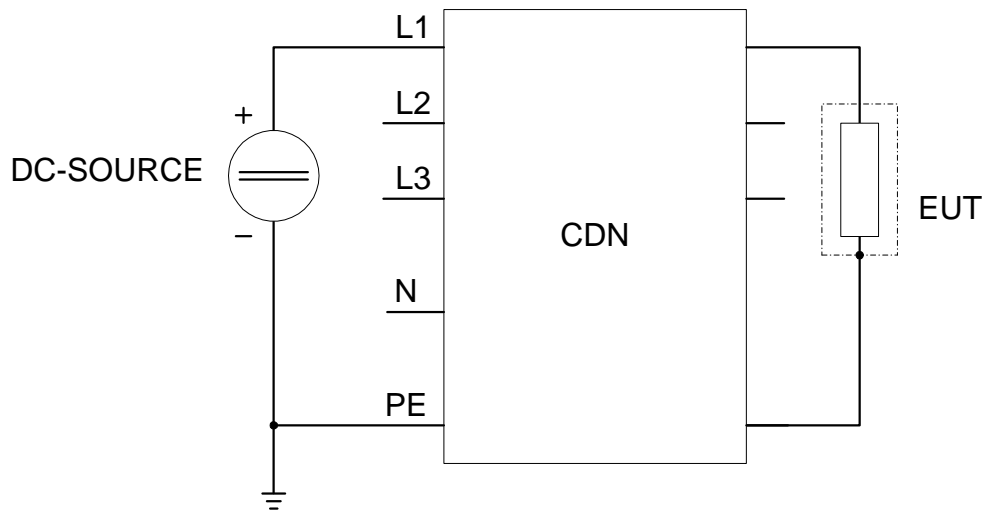

Figure 2: Two terminal source (+ and -/PE), asymmetrically to earth, any metallic case of the EUT is connected with -/PE

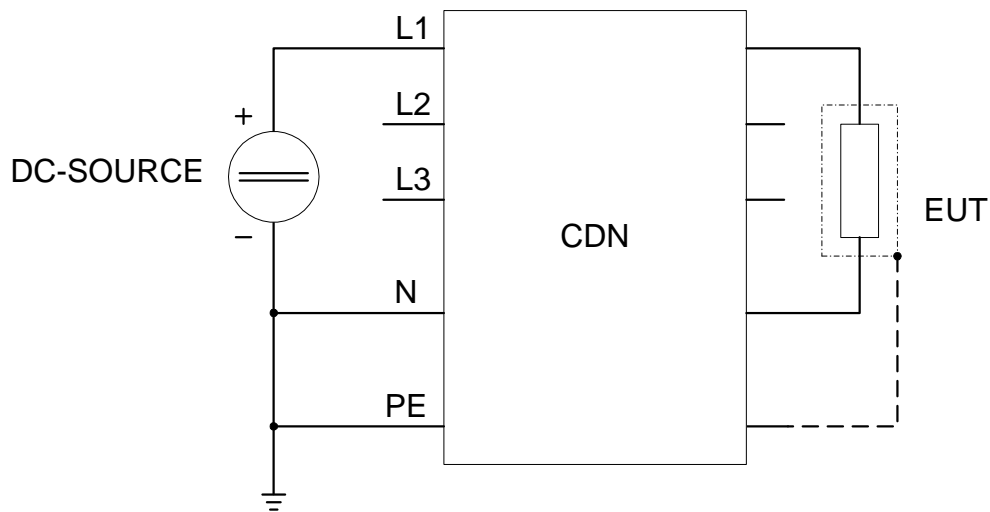

Figure 3: Three terminal source (+, - and PE), asymmetrically to earth, any metallic case of the EUT is earthed

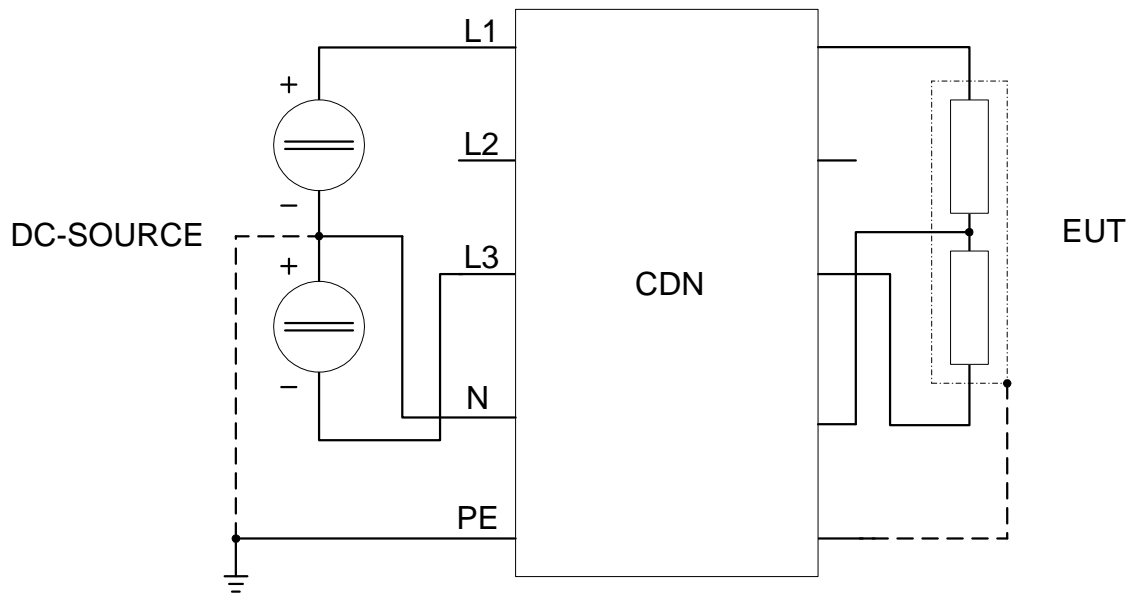

Figure 4: Three or four terminal source (+, 0, - (and PE)), symmetrically to earth or floating, used with a three phase CDN, any metallic case of the EUT is earthed

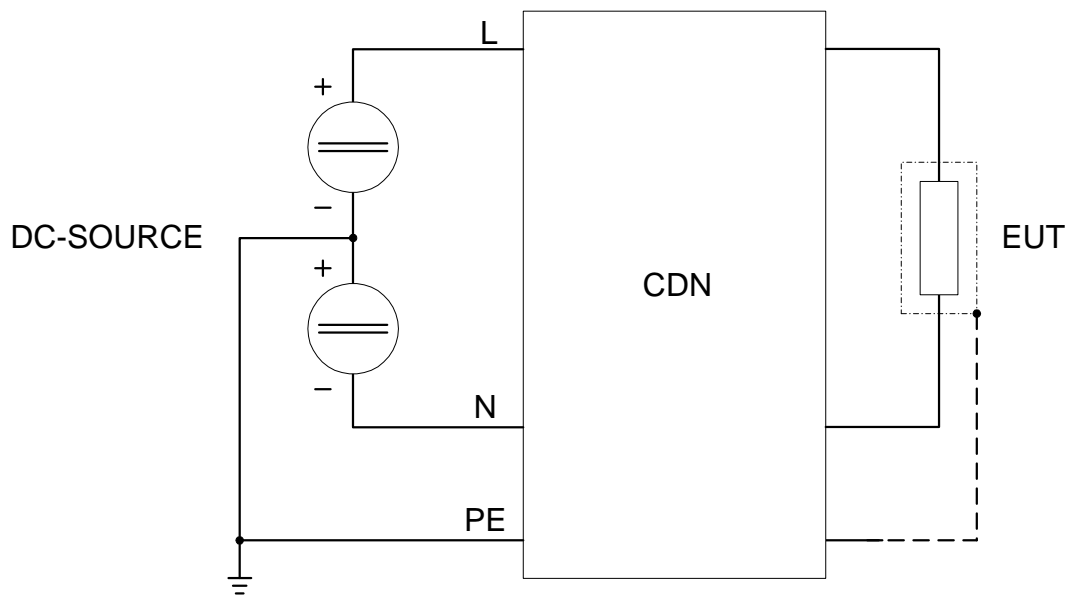

Figure 5: Three terminal source (+, - and 0/PE), symmetrically to earth, used with a single phase CDN, any metallic case of the EUT is earthed

**Note:** Voltages given in the following tables for figures 4 and 5 are the sum of both DC sources!

### 3. Tables of limits for Haefely CDNs

#### General definitions

- "Pure ohmic or ohmic-light inductive load" means a time constant of

$$T = \frac{L}{R} \leq 2.5 \text{ milliseconds.}$$

This corresponds to the utilization categories (IEC 60947-1) DC-1 and DC-3

- "Ohmic-heavy inductive load" means a time constant of  $T = \frac{L}{R} \leq 15$  milliseconds.

This corresponds to the utilization category (IEC 60947-1) DC-5

- The time constant must not exceed 15 milliseconds

L: the inductance of the EUT plus the inductance of the decoupling inductors inside the CDN (see the user manual of the individual CDN for the specific values)

R: the ohmic resistance  $R = \frac{U}{I}$  of the EUT

#### PEFT 4010, internal single phase CDN

connection according to figure 2

Voltage DC	maximum current for pure ohmic or ohmic-light inductive load	maximum current for ohmic-heavy inductive load
30V	16A	6A
60V	6A	2A
125V	-	-
220V	-	-

connection according to figure 1 and 3-5

Voltage DC	maximum current for pure ohmic or ohmic-light inductive load	maximum current for ohmic-heavy inductive load
30V	16A	10A
60V	16A	6A
125V	4A	2A
220V	-	-

#### PCD 100 or PSURGE 4010 with internal single phase CDN

connection according to figure 2

Voltage DC	maximum current for pure ohmic or ohmic-light inductive load	maximum current for ohmic-heavy inductive load
30V	16A	16A
60V	14A	6A
125V	8A	5A
220V	3A	1A

connection according to figure 1 and 3-5

Voltage DC	maximum current for pure ohmic or ohmic-light inductive load	maximum current for ohmic-heavy inductive load
30V	16A	16A
60V	16A	16A
125V	15A	15A
220V	15A	10A

**Note:** For the PSURGE 4010 single phase CDN there is a forbidden range of the DC voltage level: 160...200V. Neither DC voltage in that range must be applied to the CDN!

**PIM150 with internal three phase CDN**

connection according to figure 2

Voltage DC	maximum current for pure ohmic or ohmic-light inductive load	maximum current for ohmic-heavy inductive load
30V	12A	12A
60V	8A	5A
125V	2A	1A
220V	0.6A	-

connection according to figure 1 and 3-5

Voltage DC	maximum current for pure ohmic or ohmic-light inductive load	maximum current for ohmic-heavy inductive load
30V	16A	16A
60V	14A	6A
125V	8A	5A
220V	3A	1A

**PCD 130 or PCD 430 (standard)**

connection according to figure 2

Voltage DC	maximum current for pure ohmic or ohmic-light inductive load	maximum current for ohmic-heavy inductive load
30V	20A	16A
60V	14A	10A
125V	5A	1.2A
220V	1A	-

connection according to figure 1 and 3-5

Voltage DC	maximum current for pure ohmic or ohmic-light inductive load	maximum current for ohmic-heavy inductive load
30V	32A	22A
60V	30A	12A
125V	18A	5A
220V	5A	0.8A

**PCD 130 or PCD 430 with additional line on / off contactor  
(available only by special request)**

connection according to figure 2

Voltage DC	maximum current for pure ohmic or ohmic-light inductive load	maximum current for ohmic-heavy inductive load
30V	32A	22A
60V	30A	12A
125V	18A	5A
220V	5A	0.8A

connection according to figure 1 and 3-5

Voltage DC	maximum current for pure ohmic or ohmic-light inductive load	maximum current for ohmic-heavy inductive load
30V	32A	25A
60V	32A	25A
125V	30A	25A
220V	25A	15A

**FP-EFT 32.1, FP-SURGE 32.1 or PCD 300**

connection according to figure 2

Voltage DC	maximum current for pure ohmic or ohmic-light inductive load	maximum current for ohmic-heavy inductive load
30V	32A	32A
60V	32A	32A
125V	7A	4A
220V	1A	1A

connection according to figure 1 and 3-5

Voltage DC	maximum current for pure ohmic or ohmic-light inductive load	maximum current for ohmic-heavy inductive load
30V	32A	32A
60V	32A	32A
125V	32A	32A
220V	7A	4A

**FP-EFT 32M**

connection according to figure 2

Voltage DC	maximum current for pure ohmic or ohmic-light inductive load	maximum current for ohmic-heavy inductive load
30V	32A	12A
60V	10A	1.5A
125V	-	-
220V	-	-

connection according to figure 1 and 3-5

Voltage DC	maximum current for pure ohmic or ohmic-light inductive load	maximum current for ohmic-heavy inductive load
30V	32A	32A
60V	28A	15A
125V	10A	2A
220V	-	-

## FP-EFT 100M, FP-SURGE 100M

connection according to figure 2

Voltage DC	maximum current for pure ohmic or ohmic-light inductive load	maximum current for ohmic-heavy inductive load
24V	100A	100A
30V	100A	33A
48V	100A	-
60V	-	-
95V	-	-

connection according to figure 1 and 3-5

Voltage DC	maximum current for pure ohmic or ohmic-light inductive load	maximum current for ohmic-heavy inductive load
24V	100A	100A
30V	100A	100A
48V	100A	100A
60V	100A	33A
95V	100A	-

Headquarters  
**Haefely Test AG**  
Lehenmattstrasse 353  
CH-4052, Basel  
Switzerland

☎ + 41 61 373 41 11  
☎ + 41 61 373 45 99  
✉ [EMC-sales@haefely.com](mailto:EMC-sales@haefely.com)

Locate your local  
sales representative at  
[www.haefelyEMC.com](http://www.haefelyEMC.com)



**HAEFELY** **EMC**  
TECHNOLOGY

North American Office  
**Hipotronics Inc.**  
**Haefely EMC Division**  
1650 Route 22  
Brewster, NY 10509

☎ ++1 845 279 3644 x264  
☎ ++1 845 279 2467  
✉ [EMCsales@hubbell-haefely.com](mailto:EMCsales@hubbell-haefely.com)